



H9 DMX Fan

H-9 is a professional special auxiliary equipment, the shell adopted sturdy metal materials, firm and durable. Adjustable wind speed, wind outlet angle 270°adjustable; It can be hung used. Use with fog machine, H-9 can thin the fog, spreading further; used with snow or bubble machine, snow or bubble can spread further and higher



Power supply system and output

| | | | |
|-----------|--------------|-----------------|------------------------------------|
| Voltage | 240V 50Hz | Fan Speed | 0 - 2500r / min |
| Power | 150W | Control | DMX, Wireless remote, Stand alone. |
| Fan Angle | 0 - 270 deg. | DMX Personality | 1 channel |

Appearance parameters

| | | | |
|-----------|-------|------------|-------------------|
| Structure | Steel | Size | 450 x 260 x 480mm |
| IP Rate | IP20 | Net weight | 11.3 Kg |

| Channel | DMX Value | Function |
|---------|-----------|----------------|
| 1 | 0 - 9 | Off |
| | 10 - 255 | Fan Low > High |

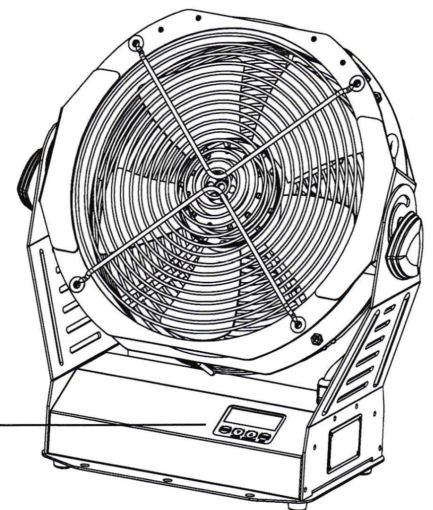
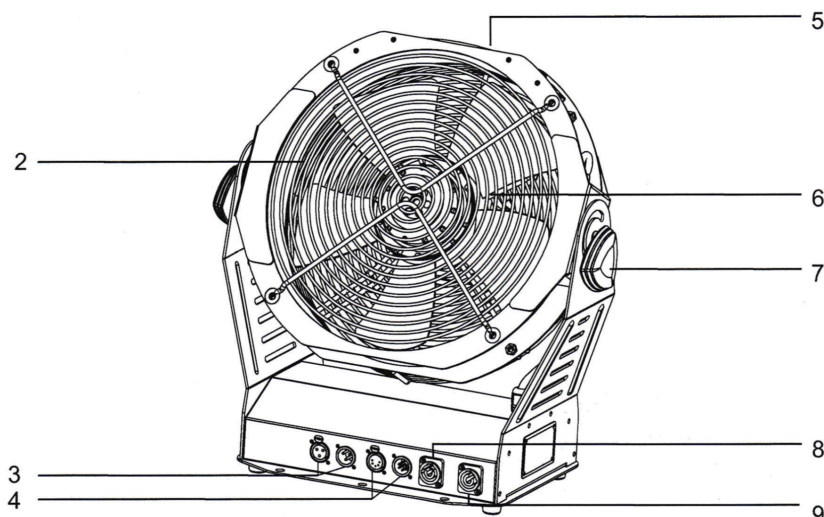

1. Fan grid
2. LCD display
3. 3-pin DMX
4. 5-pin DMX
5. Trolley
6. Fan blade
7. Knob
8. Power in
9. Power out